

USER MANUAL

RA00268

90150

BRUSHLESS + BRUSHED
over 3.0T (brushless)
over 4T (brushed)



for distributor address see packaging

www.nosram.com

1. INSTALLATION

The NOSRAM MATRIX POWER BRUSHLESS REVERSE is supplied with 3.3mm² power-wires without connectors. Be very careful with the correct wire sequence/colors since an incorrect connection may damage the speed-control! Avoid creating solder bridges on the solder-tabs and isolate all connections carefully.

Caution: Avoid soldering longer than 5sec per soldering joint when replacing the power wires on the speed-control and motor to prevent possible damage due to overheating of the components!

- Connect the speed-control to the receiver (position: Channel 2)

BRUSHLESS MOTOR:

- Blue power-wire Speedo MOT.A to motor „A“
- Yellow power-wire Speedo MOT.B to motor „B“
- Orange power-wire Speedo MOT.C to motor „C“
- Connect the hall sensor cable to the speed-control and the motor.

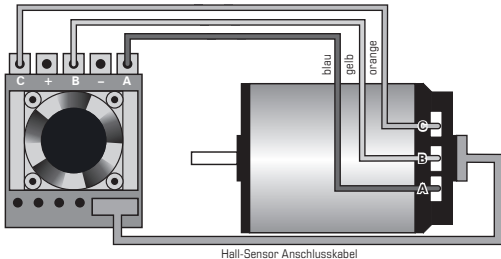

Hall-Sensor Anschlusskabel

BRUSHED MOTOR:

- MOT.A (blue) and MOT.B (yellow) will be the combined „minus“ on the brushed motor.
- MOT.C (orange) wire will be „plus“ on the brushed motor.

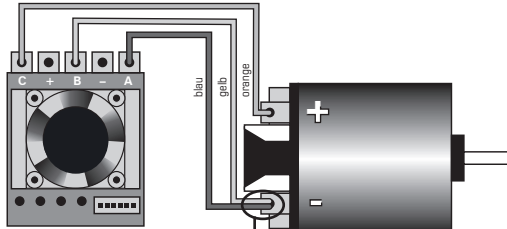

Gemeinam auf Minus

- Doublecheck all connections before connecting the speed-control to a battery.
- Caution:** If battery is connected with reversed polarity it will destroy your speed-control!
- Red power-wire ▶ Speedo BAT+ to battery „Plus“
- Black power-wire ▶ Speedo BAT- to battery „Minus“
- The speed-control is now ready to be set-up (see section 6).

2. CONNECTIONS

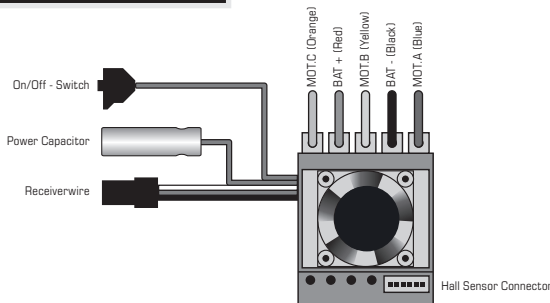

RECEIVER CONNECTING WIRE:

This speed-control is equipped with an NOSRAM Multicon receiver wire. As supplied, it will easily fit in all ordinary receivers.

HALL SENSOR WIRE:

This bi-directional multiple wire connects the speed-control and the motor. Do not alter or modify this cable! There are replaceable/optional hall sensor wires available: • #92510 (20cm) • #92520 (10cm)

POWER WIRE:

For maximum performance, 3.3mm² power wires without any connectors are used. The unique splitted solder-tabs allow easy and convenient replacement of the power wires. Nevertheless some soldering skills are required. Avoid soldering longer than 5sec per soldering joint to prevent possible damage to the speed-control due to overheating of the components! There is a full 2.6mm² replacement power wire set available: #92506

Caution: Be very careful with the correct wire sequence since an incorrect connection may damage the speed-control! Avoid creating solder bridges on the solder-tabs and isolate all connections carefully. Avoid soldering longer than 5sec per soldering joint.

Dear Customer,

thank you for your trust in this NOSRAM product. By purchasing a NOSRAM MATRIX BRUSHLESS POWER REVERSE speed-control, you have chosen one of the most advanced speed-controls of today. This speed-control with all of its high-tech features and specially selected electronic components is offering great value for the money.

- 4 speed controls in 1 (Brushless, Brushed, Fwd/Brk/Rvs, Fwd/Brk)
- 4 fully adjustable modes
- Sensored Design
- Advanced Digital
- Small and Lightweight
- FreezeDrive Design
- SmartCell System
- Internal-Temp-Check system
- 4, 5, and 6 cell optimised
- Big Power Capacitor
- 3.3mm² Power-Wires

Please read the following instructions carefully before you start using your NOSRAM MATRIX BRUSHLESS POWER REVERSE speed control. This user guide contains important notes for the safety, the use and the maintenance of this product. Thus protecting yourself and avoid damages of the product.

Proceed according to the user guide in order to understand your NOSRAM MATRIX BRUSHLESS POWER REVERSE speed control better. Please take your time as you will have much more joy with your product if you know it exactly.

This user manual shall be kept in a safe place. If another customer is using this product, this manual has to be handed out together with it.

3. SPECIFICATIONS

Brushless + Brushed	yes	Typ. Voltage Drop (Brushed) ⁴	@20A - 0.010V
Brushless + Brushed adaption	AUTOMATIC	Rated Current (Brushed) ⁴	400A
Forward/Brake	yes	B.E.C.	6.0V/3.0A
Forward/Brake/Reverse	yes	High Frequency	yes
Case Size	33.1x37.6x32.5mm	Sensored Brushless System	yes
Weight (excl. wires)	45g	Multi-Protection-System	yes
Voltage Input	4.8-8.4V	Power Wire	3.3mm ²
Rec. Motor Limit for Star-winds (Brushless) ²	over 3.0 turns	4, 5, 6 cell optimised	yes
Rec. Motor Limit (Brushed) ²	über 4 turns	Internal-Temp-Check System	yes
Typ. Voltage Drop (Brushless) ⁴	@20A - 0.013V / phase		
Rated Current (Brushless) ⁴	400A / phase		
Compatible winding styles (Brushless)	Star		
4 adjustable modes (NiMH/LiPo, Forward/Brake - Forward/Brake/Reverse, Power Profiles, Auto-Brake)	yes		

⁴ Transistors rating at 25°C junction temperature measured at 7.2V

² Specifications subject to change without notice.

4. INSTALLATION TIPS

- Mount the speedo using the supplied thick/black doubled-sided tape.
- Position the speed-control where it is protected in the event of a crash.
- Install the speed-control so that you have easy access to the connector and buttons.
- Make sure there is enough clearance (about 3cm) between the speed-control, power-wires, antenna and receiver. Avoid any direct contact between power components, the receiver or the antenna. This can cause interference. If interference occurs, position the components at a different place in the model.
- The aerial should be run vertically up and away from the receiver. Avoid contact with any parts made of carbon fibre or metal. If the aerial is too long, don't coil up the excess length. It is better to cut it down to a length of about 35 cm. See also the instructions supplied with your radio control system.
- Make sure there are enough cooling slits in the body. This will increase the performance and life of all the electronic components.

HEATSINK: To achieve best performance even under extreme conditions, the heatsink has been directly mounted to the speed-control. This ensures the best possible heat transfer away from the speed-control.

Caution: Never attempt to remove the heatsink, because the speed-control will get damaged if you do this. The heatsink is an integral part of the speed-control and therefore cannot be removed.

Because of the physical principles of brushless technology, the speed-controls do get a little hotter than brushed systems. Therefore it is required to let the speed-control cool down completely after every run.



NOSRAM MATRIX BRUSHLESS POWER REVERSE with heat sink.



Mount the power-capacitor in a position where it is protected in the event of a crash. The best place is right next to the speed-control (see picture). Secure it with doublesided tape.

5. SUPPRESSION

Mabuchi motor



Racing motor

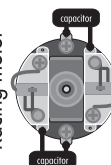

ONLY FOR BRUSHED MOTORS! Motors with no capacitors or not enough capacitors may interfere with the speed-control. To avoid this, solder the supplied capacitors to your motor (see picture).

6. RADIO / SPEED-CONTROL SET-UP

In setup mode the NOSRAM MATRIX BRUSHLESS POWER REVERSE stores every step when you press the SET button. All the settings will be stored in the speed-controls memory even if the speed-control will be disconnected from the battery.

TRANSMITTER SETTINGS

Setup the following basic functions on your transmitter (if available):

Throttle travel	High ATV, EPA	maximum
Brake travel	Low ATV, EPA, ATL	maximum
Throttle exponential	EXP, EXPO	start with 0
Neutral trim	SUB Trim	centre
Servo reverse	Throttle reverse	any setting, don't change after set-up procedure!

If your transmitter doesn't offer any of above functions, it's already in „basic setup“ mode.

- Ensure that the speed-control is not connected to the drive battery and is switched off.
- Remove motor pinion or ensure that the wheels of the model are free to rotate.
- Switch the transmitter on and set the transmitter throttle stick to neutral.

- Connect the speed-control to the battery, and switch the unit on.
- Hold the SET button pressed for at least 3sec using the supplied plastic screwdriver.
 - ▶ You entered setup mode and the SET LED flashes red (it will flash until the setup is completed).

- Leave transmitter in neutral position and press the SET button once.
 - ▶ Neutral setting is stored, MODE LED flashes green and the motor beeps.
- Hold full throttle on transmitter and press the SET button once.
 - ▶ Full-throttle setting is stored, MODE LED flashes red.
- Hold full reverse on transmitter and press the SET button once.
 - ▶ Reverse setting is stored, LED's glow red (MODE) and red (SET).

- This completes the setup procedure and your NOSRAM MATRIX BRUSHLESS POWER REVERSE is ready to use.
- If you make a mistake during the setup procedure, don't worry: Disconnect the battery for about 10sec and start again from the first step.
- At the end of each run switch of the car, and then switch off the transmitter.
- At the start of each run switch on the transmitter first, then switch on the car.
- For storage of the car, disconnect the drive battery at any time!

CHECKING THE FUNCTIONS:

Check the LED's when moving your throttle stick and you will see if everything is setup correctly.

FUNCTION	STATUS	MODE LED	SET LED
Neutral (automatic brake inactive)	--	off	red
Neutral (automatic brake active)	--	red	off
Forward	partial throttle	green	off
Forward	full throttle	green	red
Brake/Reverse	partial brake/reverse	red	off
Brake/Reverse	full brake/reverse	red	red

7. MODE PROGRAMMING

All modes are available for brushless and brushed motors (speedo adapts automatically). The NOSRAM MATRIX BRUSHLESS POWER REVERSE features 4 modes which enable you to adjust it to YOUR special requirements. The factory settings are shown in grey colour.

- How to get into „programming the modes“
 - ▶ Press MODE button for 3 or more seconds.
- How to check the stored values
 - ▶ Count the number of flashes of the red SET-LED (1x = value 1, 2x = value 2, etc.).
- How to change the value
 - ▶ Press SET button to increase value by one step.
- How to get to the next Mode
 - ▶ Press MODE button once.
- How to leave the programming mode
 - ▶ If you are in MODE.4, press the MODE button one more time
- Table of settings, values and modes: see below (grey-shaded values show „works default settings“)

MODE.1 - SmartCell System

we recommend using value 2 for 4-6 cells NiMH racing purposes, which disengages the LiPo protection.

MODE LED	Value 1	Value 2
Green	LiPo Mode	NiMH Racing Mode

MODE.2 - Forward/Brake/Reverse - Forward/Brake

the NOSRAM MATRIX BRUSHLESS POWER REVERSE contains 4 speed-controls in 1! Brushless or brushed it adapts automatically and here you can select between forward/brake/reverse and forward/brake „racing style“ operation.

MODE LED	Value 1	Value 2
Red	Forward Reverse	Forward Brake

MODE.3 - Power Profiles

allows you to adjust the NOSRAM MATRIX BRUSHLESS POWER REVERSE to your likes. Either you run on slippery or high-traction surfaces, we have incorporated a profile for you! Higher value means more overall power and more aggressive throttle response.

MODE LED	Value 1	Value 2	Value 3	Value 4
Green/Red (alternate)	Smooth	Linear	Progressive	Aggressive

MODE.4 - Auto-/Dragbrake

allows you to set a slight braking action which is applied in the neutral range. This enables you to simulate the feel of a brushed motor and also hold the throttle on longer when entering a turn. Your car also has more front traction with this setting. For brushless motors you achieve the same natural slowdown as a brushed motor with no autobrake when you set value 1-2 (for motors with bonded magnets) or 0-1 (for motors with sintered magnets).

MODE LED	Value 0	Value 1	Value 2	Value 3	Value 4
Green/Red (same time)	No Automatic Brake	increasing from low (#1) to high (#4) autobrake settings			

8. SPECIAL FEATURES

Internal-Temp-Check System: the NOSRAM MATRIX BRUSHLESS POWER REVERSE allows you to read-out the maximum internal temperature that the speedo reached. To save it to the memory you have to briefly apply brakes after the run before you turn the switch off. You can conveniently read-out the temperature back in the pits since it remains stored until you turn it on the next time regularly (which will reset the memory). This new feature allows you to accurately check if all is running well or if you're close to shutdown already.

How to read-out the temperature:

- ▶ Switch at „OFF“ position.
- ▶ Keep MODE button pressed while you turn switch to „ON“ (then release button)
- ▶ SET LED will start to flash red (MODE LED is off), now count the number of flashes.

Basics:

- Thermal shutdown of the speedo would occur at 6 flashes.
- The higher the number of flashes, the cooler the speedo ran (e.g. the better it is!)
- Every flash equals to -8°C temperature decrease

Example:

- ▶ you count 10 flashes after the run
- ▶ 10 - 6 = 4 (e.g. 4 flashes „away“ from shutdown)
- ▶ 4 x 8°C = 32°C (e.g. you are 32°C away from thermal shutdown and therefore safe!)

SmartCell System: Ready for the next battery technology – LiPo batteries! NOSRAM's exclusive and smart SmartCell System ensures that LiPo batteries can be used safely without accidentally deep-discharging of the cells. The motor function will be shut-off and the SET LED will flash if the system recognises very low battery voltage.

Tip We recommend using value 2 for 4-6 cells NiMH racing purposes, which disengages the LiPo protection.

Automatic Brushless / Brushed Adaption: The NOSRAM exclusive Automatic Brushless/Brushed Adaption detects the connected motor type during turn-on/initialisation and adjusts the correct brushless or brushed operation automatically. No adjustments required by yourself, apart from the correct connection of each motor type (don't forget the hall-sensor-wire for brushless!).

Caution: Keep in mind, when swapping between brushless and brushed motors, that the chosen mode values will be identical!

Changing Mode settings without the transmitter: At race events you usually do not have access to your transmitter, but never mind since you can simply disconnect the receiver lead from the receiver and change the MODE settings as described in section 7 „Mode Programming“.

FreezeDrive Design: NOSRAM's secret FreezeDrive Design results in lower speedo temperature under all racing conditions and for both brushless + brushed. Sorry, no further details to be disclosed. Simply a step ahead of the competition!

Works-Default-Settings: All NOSRAM speed-controls come factory-adjusted (defaults are grey-shaded above). If you loose track of the modes, you can restore the works default settings. With the transmitter switched on, hold the SET button pressed while you switch on the speed-control. This simple action returns the unit to the NOSRAM works default settings.

Power Capacitor: Never disconnect the power-capacitor! It is required for proper function, a special SuperLow ESR type has been chosen, which offers increased punch and additional protection, therefore only use genuine NOSRAM power capacitors.

Sensored Brushless Technology: Advanced Digital allows the perfect knowledge of the brushless motor's magnet position. This results in perfect motor control at high and low RPM's, as well as perfect brake control.

3-Way Protection System: The perfect protection against short-circuits (motor), overload and overheating. If your speed-control faces overload, the motor function will be shut-off for protection and the SET LED will flash, although the steering function is maintained. Let the speed-control cool down for a few minutes. If you experience frequent shutdowns, check for the following:

- Correct gear ratio (refer to motor manual for gearing recommendations)
- ADPC setting too high (higher value will heat up motor and speed-control excessively)
- Motor is too strong or motor is damaged.

9. TROUBLESHOOTING GUIDE

EXPLANATION: If no remark, cause can be either with brushless or brushed motor. If „BM“ is indicated, cause only relating to brushed motor.

SYMPTOM	CAUSE	REMEDY	
Servo is working, no motor function.	Speed-control plugged in incorrectly	Plug speed-control in Ch 2	
	Overload protection activated	Allow speed-control to cool down	
	Wiring problem	Check wires and plugs	
	Motor defective	Replace motor	
	BM - Motor brushes stuck	Check that brushes are moving freely	
No servo and no motor function.	Speed-control defective	Send in product for repair	
	Speed-control plugged in incorrectly	Plug speed-control in with correct polarity	
	Crystal defective	Replace components one by one.	
	Receiver defective		
Transmitter defective			
Motor runs in reverse when accelerating forward on the transmitter.	Speed-control defective	Send in product for repair	
	BM - Motor connected incorrectly	Connect motor correctly	
	Insufficient performance. E.g. poor brake power, topspeed or acceleration..	Motor pinion too big or gear ratio too long. Transmitter settings changed after set-up	Use smaller motor pinion/shorter gear ratio Repeat set-up procedure
Speed-control overheats or switches off frequently.	BM - Motor worn out	Maintain motor	
	Motor defective	Replace motor	
	Speed-control defective.	Send in product for repair	
	Motor stronger than motor/limit or input voltage too high	Use only motors and batteries which are within the specifications of the speed-control	
Motor never stops, runs at constant slow speed	Motor pinion too big or gear ratio too long.	Use smaller motor pinion/shorter gear ratio	
	Drive train or bearing problems.	Check or replace components.	
	Model used too often without cool-down periods	Let speed-control cool down after every run	
Radio interference	Transmitter settings changed after set-up	Repeat set-up procedure	
	Humidity/water in speed-control	Immediately unplug and dry speed-control	
Speed-control overheats or switches off frequently.	Speed-control defective	Send in product for repair	
	BM - Motor suppressors not sufficient	Solder capacitors to motor	
	Receiver or antenna too close to power wires, motor, battery or speed-control.	Receiver antenna too short or coiled up	See „Installation Tips“ and „Installation“
	Receiver defective, too sensitive;	Transmitter defective, transmitter output power too low, servo problem	Replace components one by one Only use original manufacturers crystals
	Poor battery connection	Check plugs and connecting wires	
	Transmitter batteries empty	Replace / recharge transmitter batteries	
	Transmitter antenna too short	Pull out antenna to full length	